

SLMB-TC1-1-43X

Features

- wideband, 650 to 4000 MHz
- balanced transmission line
- good return loss
- excellent amplitude unbalance, 0.5 dB typ. and phase unbalance, 3 deg typ. in 1 dB bandwidth
- plastic base with leads
- aqueous washable

Applications

- balanced to unbalanced transformation
- push-pull amplifiers
- PCS/DCS
- MMDS



Transformer Electrical Specifications

Ω RATIO	FREQUENCY (MHz)	INSERTION LOSS*	PHASE UNBALANCE (Deg.) Typ.	AMPLITUDE UNBALANCE (dB) Typ.
1	650-4000	1dB 650-4000	5	0.6

* Insertion Loss is referenced to mid-band loss, 0.3 dB typ.

50Ω 650 to 4000 MHz

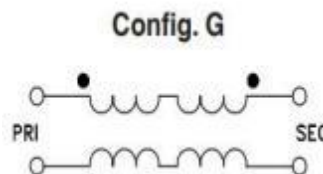

Typical Performance Data

FREQUENCY (MHz)	INSERTION LOSS (dB)	INPUT R. LOSS (dB)	AMPLITUDE UNBALANCE (dB)	PHASE UNBALANCE (Deg.)
650.00	0.30	19.40	0.72	7.04
700.00	0.30	19.03	0.70	6.11
800.00	0.32	19.01	0.65	4.73
1000.00	0.35	18.85	0.50	3.45
1600.00	0.45	16.34	0.15	0.32
2000.00	0.53	15.36	0.05	0.42
2600.00	0.62	16.20	0.40	0.66
3000.00	0.57	20.76	0.56	1.07
3800.00	1.34	9.18	0.41	4.79
4000.00	1.71	7.51	0.09	5.95

Maximum Ratings

Operating Temperature -20°C to 85°C

Storage Temperature -55°C to 100°C

RF Power 0.5W

DC Current 30mA

Permanent damage may occur if any of these limits are exceeded.

Outline Drawing

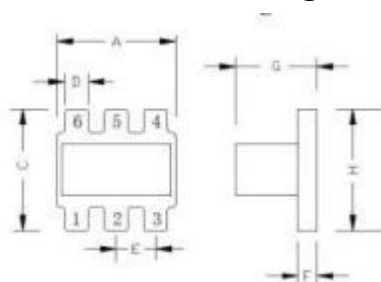

Outline Dimensions (mm)

A	3.81	N	1.53
B	-	M	1.27
C	3.81	P	0.76
D	0.75		
E	1.27		
F	0.61		
G	2.61		
H	3.81		
J	3.3		
K	4.83		
L	1.65		
WT			

Pin Connections

PRIMARY DOT	6
PRIMARY	4
SECONDARY DOT	1
SECONDARY	3
NOT USED	2

PCB Land Pattern

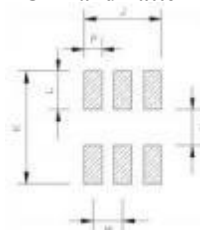

Features

- ultra wide bandwidth 10 to 8000 MHz
- one model covers all telecommunication bands
- flat insertion loss
- good return loss
- aqueous washable
- 50Ω

Applications

- differential modulator/ demodulator and active mixers
- wideband push- pull amplifiers
- LTE, Cellular, PCS, UMTS, WiFi, WiMAX



Transformer Electrical Specifications at 25°C				
Impedance Ratio	Frequency Range (MHz)	INSERTION LOSS* (dB)	PHASE UNBALANCE (Deg.)	AMPLITUDE UNBALANCE (dB)
1	10 ~ 8000	10~8000MHz 1.3~3	10~6000MHz 8 6000~8000MHz 4 Typ.	Typ.

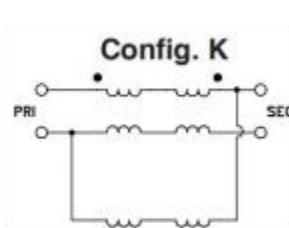

Typical Performance Data				
FREQUENCY (MHz)	INSERTION LOSS (dB)	INPUT R. LOSS (dB)	AMPLITUDE UNBALANCE (dB)	PHASE UNBALANCE (Deg.)
10	1.70	15.68	0.06	0.26
100	1.65	16.28	0.07	1.19
1000	1.57	16.28	0.26	7.54
2000	1.29	16.90	0.46	11.37
3000	1.29	13.75	0.52	13.20
4000	1.49	10.32	0.57	11.96
5000	0.96	10.42	0.36	11.99
6000	0.98	13.09	0.28	7.84
7000	1.16	14.40	1.14	0.81
8000	1.80	14.73	1.39	4.57

Maximum Ratings	
Operating Temperature	-40°C to 85°C
Storage Temperature	-55°C to 100°C
RF Power	0.2W
DC Current	30mA
Permanent damage may occur if any of these limits are exceeded.	

Outline Drawing

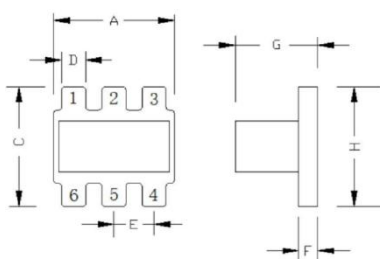

Outline Dimensions (mm)			
A	3.81	N	1.53
B	-	M	1.27
C	3.81	P	0.76
D	0.76	H	3.81
E	1.27	J	3.3
F	0.61	K	4.83
G	2.61	L	1.65
WT	0.16G		

Pin Connections

PRIMARY DOT	3
PRIMARY	2
SECONDARY DOT	5
SECONDARY	4
GND	2
NOT USED	1, 6

PCB Land Pattern

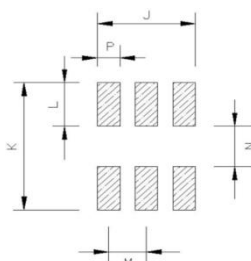

SLMB - TCM1 - 63AX

Features

- ultra wide bandwidth 10 to 6000 MHz
- one model covers all telecommunication bands
- flat insertion loss
- good return loss
- aqueous washable
- 50Ω 10 to 6000 MHz

Applications

- differential modulator/demodulator and active mixers
- wideband push-pull amplifiers
- LTE, Cellular, PCS, UMTS, WiFi, WiMAX

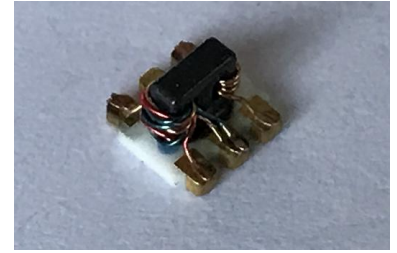

50Ω 10 to 6000 MHz

Config. K

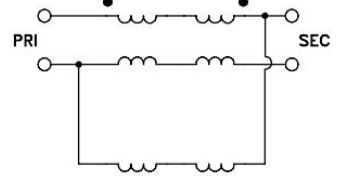

Transformer Electrical Specifications at 25°C

Impedance Ratio	Frequency Range (MHz)	INSERTION LOSS* (dB) 10~6000MHz	PHASE UNBALANCE (Deg.) Typ.	AMPLITUDE UNBALANCE (dB) Typ.
1	10 ~ 6000	1.3~2.5	8	0.5

Typical Performance Data

FREQUENCY (MHz)	INSERTION LOSS (dB)	INPUT R. LOSS (dB)	AMPLITUDE UNBALANCE (dB)	PHASE UNBALANCE (Deg.)
10	1.70	14.78	0.06	1.15
100	1.65	16.28	0.07	1.32
500	1.57	16.28	0.26	5.05
1000	1.40	16.90	0.46	8.03
1500	1.29	15.98	0.52	9.87
2000	1.29	13.74	0.57	10.96
3000	1.49	9.42	0.36	10.99
4000	1.20	11.09	0.28	8.84
5000	1.16	13.40	0.96	5.19
6000	1.80	10.73	1.39	0.57

Maximum Ratings

Operating Temperature	-40°C to 85°C
Storage Temperature	-55°C to 100°C
RF Power	0.2W
DC Current	30mA
Permanent damage may occur if any of these limits are exceeded.	

Pin Connections

PRIMARY DOT	3
PRIMARY	2
SECONDARY DOT	6
SECONDARY	4
GND	2
NOT USED	1,5

Outline Drawing

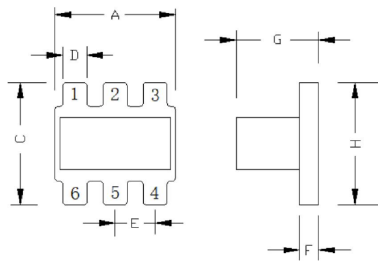

PCB Land Pattern

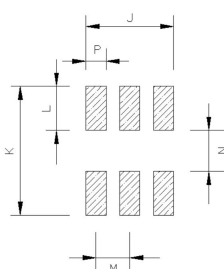

Outline Dimensions (mm)

A	3.81	N	1.53
B	-	M	1.27
C	3.81	P	0.76
D	0.76		
E	1.27		
F	0.61		
G	2.61		
H	3.81		
J	3.3		
K	4.83		
L	1.65		
WT	0.05g		

Dimensions

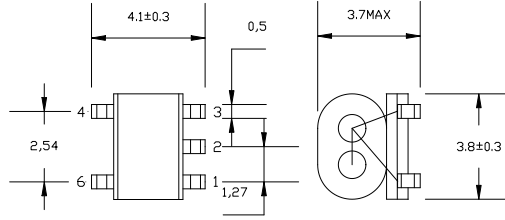

Maximum Ratings

Operating Temperature	-40°C-85°C
Storage Temperature	-55°C-100°C
RF Power	0.25W

Pin Connections

Primary Dot	4
Primary	6
Secondary	1
Secondary Dot	3

Recommended Patterns

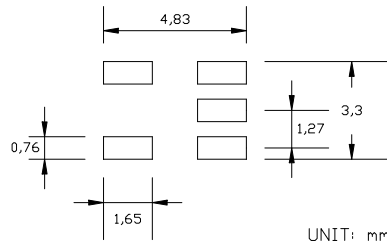

Electrical Specifications: $T_A = 25^\circ\text{C}$, 0dBm, $Z_0 = 50 \Omega$

Parameter	Test Conditions	Units	Min	Type	Max
Insertion Loss	700 - 1900 MHz	dB	-	0.5	1.2
Amplitude Unbalance (Nominal 0dB)	700 - 1900 MHz	dB	-	0.05	± 0.1
Phase Unbalance (Nominal 180°)	700 - 1900 MHz	deg	-	1	± 2
Input Return Loss	700 - 1900 MHz	dB	6	12	-

Schematic

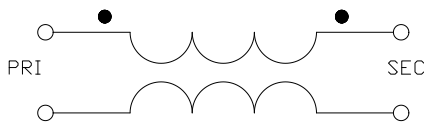

Test circuit

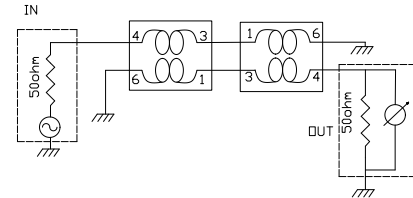

Typical Performance Curves: $T_A = 25^\circ\text{C}$, 0dBm, $Z_0 = 50\Omega$

Insertion Loss

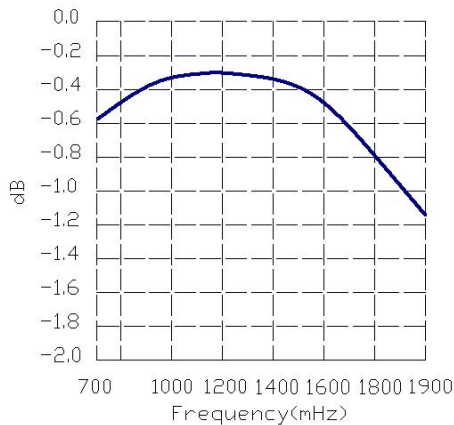

Return Loss

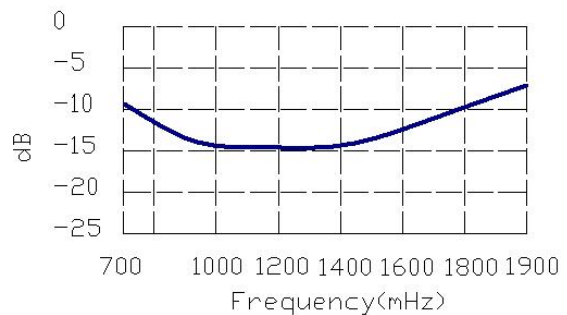

Package

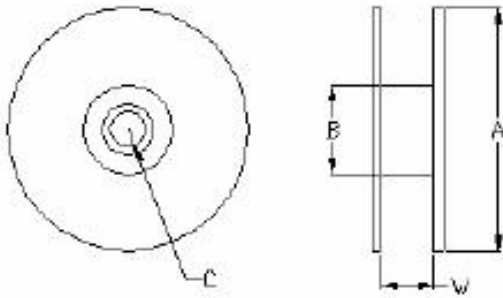

Dimensions of reel (mm)				Packing Unit
A	B	C	W	Φ330mm
330	100	13.5	12.5	2000pcs/reel

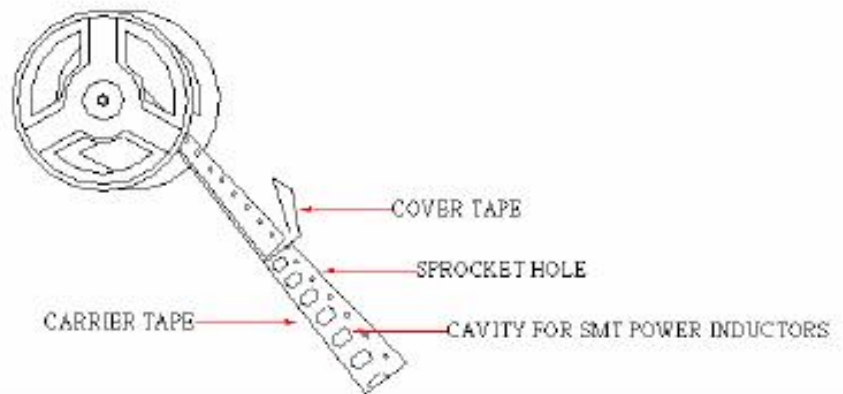
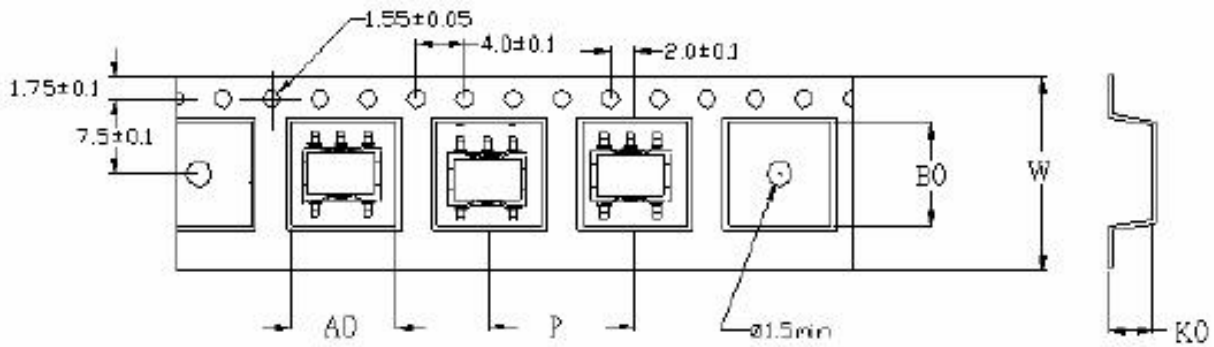

SLMB-TC4-19

Features

- Suitable for tin/lead and RoHS solder systems
- Wideband, 10-1900 MHz
- Balanced transmission line with secondary center tap
- Aqueous washable

Applications

- PCS
- Cellular



Electrical Specifications at 25°C					
Parameter	Frequency(MHz)	Min.	Typ.	Max.	Unit
Impedance Ratio (Secondary/Primary)			4		
Frequency Range		10		1900	Mhz
Insertion Loss	10-1900		3		dB
	20-1000		2		
	30-700		1		
Amplitude Unbalance	30-700		0.3		dB
	20-1000		0.5		
Phase Unbalance	30-700		4		Degree
	20-1000		6		

50Ω 10 to 1900 MHz

Maximum Ratings	
Operating Temperature	-20°C to 85°C
Storage Temperature	-55°C to 100°C
RF Power	0.25W
DC Current	30mA
Permanent damage may occur if any of these limits are exceeded.	

Typical Performance Data at 25° C				
FREQUENCY (MHz)	INSERTION LOSS (dB)	INPUT R. LOSS (dB)	AMPLITUDE UNBALANCE (dB)	PHASE UNBALANCE (deg.)
10.00	1.24	16.03	0.06	0.03
50.00	1.04	19.54	0.04	0.39
100.00	0.99	19.98	0.01	0.83
500.00	1.13	14.68	0.02	3.20
700.00	1.24	12.43	0.17	3.49
1000.00	1.55	9.92	0.49	3.74
1200.00	1.80	8.83	0.85	3.53
1500.00	2.34	7.69	1.47	3.59
1700.00	2.64	7.26	1.74	4.43
1900.00	2.99	7.01	1.95	4.99

Pin Connections	
PRIMARY DOT	6
PRIMARY	4
SECONDARY DOT	3
SECONDARY	1
SECONDARY CT	2

Outline Drawing

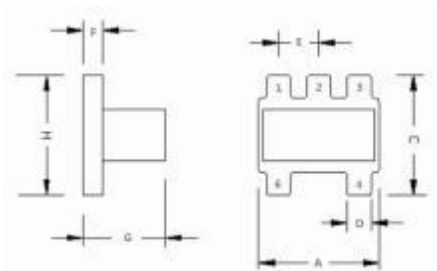

Config. H

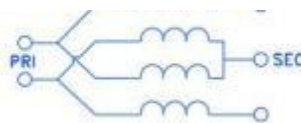

Outline Dimensions (mm)			
A	3.81	N	-
B	-	M	1.27
C	3.81	P	0.76
D	0.76	J	-
E	1.27	K	4.81
F	0.61	L	1.30
G	2.83	H	3.81
WT	0.16g		

PCB Land Pattern

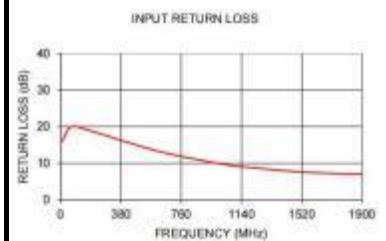
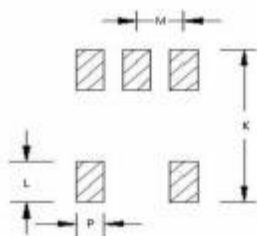

SLMB-TC2-1T

Features

- usable over 3–300 MHz
- Excellent amplitude unbalance (0.5 dB typ) and phase unbalance (4 deg. typ) in 1 dB bandwidth
- good return loss
- plastic base with leads
- aqueous washable

Applications

- VHF/UHF receivers/transmitters
- push-pull amplifiers

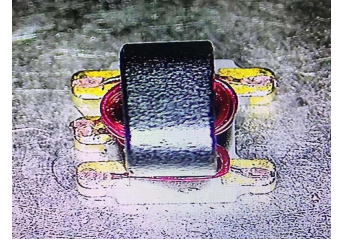

50Ω 3 to 300 MHz

Config. A

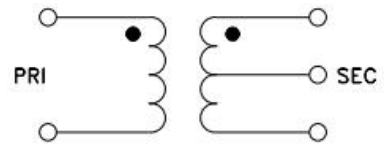

ELECTRICAL SPECIFICATIONS AT 25°C

Parameter	Frequency (MHz)	Min.	Typ.	Max.	Unit
Impedance Ratio (primary/secondary)			2		
Frequency Range		3		300	MHz
Insertion Loss*	—		3		dB
	3-300		2		
Amplitude Unbalance	—		0.5		dB
	3-300		4		
Phase Unbalance	3-300		4		Degree

* Insertion Loss is referenced to mid-band loss, 0.4 dB typ.

TYPICAL PERFORMANCE DATA

FREQUENCY (MHz)	INSERTION LOSS (dB)	INPUT R. LOSS (dB)	AMPLITUDE UNBALANCE (dB)	PHASE UNBALANCE (Deg.)
3.00	0.38	21.63	0.05	0.54
5.00	0.33	20.24	0.04	0.57
10.00	0.34	19.32	0.02	0.45
50.00	0.37	19.41	0.03	0.56
70.00	0.40	19.34	0.04	0.64
100.00	0.44	19.00	0.07	0.86
150.00	0.52	18.11	0.14	1.30
200.00	0.60	17.06	0.25	1.68
300.00	0.80	15.00	0.53	2.44

Maximum Ratings

Operating Temperature -20°C to 85°C

Storage Temperature -55°C to 100°C

RF Power 0.5W

DC Current 30mA

Permanent damage may occur if any of these limits are exceeded.

Outline Drawing

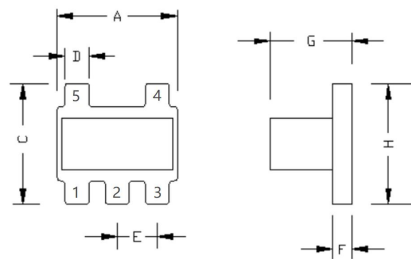

Outline Dimensions (mm)

A	3.81	N	-
B	-	M	1.27
C	3.81	P	0.76
D	0.76		
E	1.27		
F	0.61		
G	2.61		
H	3.81		
J	-		
K	4.81		
L	1.30		
WT	0.1		

Pin Connections

- PRIMARY 5
- SECONDARY CT 2
- PRIMARY DOT 4
- SECONDARY 1
- SECONDARY DOT 3

PCB Land Pattern

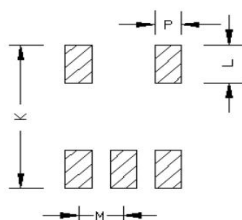

SLMB-TC1-15X

Features

- wideband,350~1500 MHz,
- good return loss
- plastic base with leads
- aqueous washable

Applications

- impedance matching
- push-pull amplifiers
- catv

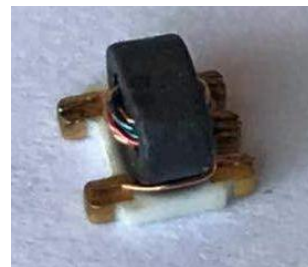

50Ω 350 to 1500 MHz

Transformer Electrical Specifications

Ω RATIO (Secondary/ Primary)	FREQUENCY (MHz)	INSERTION LOSS* (dB)
1	350~1500	2

Config. G

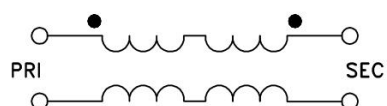

Typical Performance Data

FREQUENCY (MHz)	INSERTION LOSS (dB)	INPUT R. LOSS (dB)
350.00	0.46	8.47
360.00	0.56	8.38
470.00	0.71	7.92
580.00	0.86	7.58
690.00	0.59	8.03
800.00	0.60	8.62
975.00	0.48	11.81
1150.00	0.38	19.36
1325.00	0.43	29.22
1500.00	0.50	30.48

Maximum Ratings

Operating Temperature -40°C to 85°C
Storage Temperature -55°C to 100°C
RF Power 0.25 W
DC Current 30 mA
Permanent damage may occur if any of these limits are exceeded.

Outline Drawing

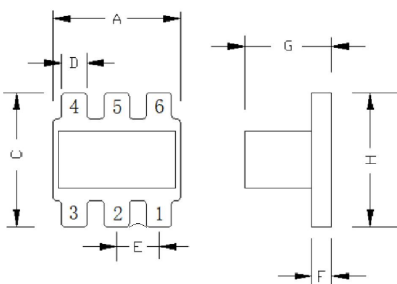

Outline Dimensions (mm)

Dimension	Value	Code	Value
A	3.80	N	1.53
B	-	M	1.27
C	4.20	P	0.76
D	0.73	G	2.80
E	1.27	H	4.20
F	0.65	J	3.30
		K	4.83
		L	1.65
WT	0.06		

Pin Connections

PRIMARY	4
NO USED	2
PRIMARY DOT	6
SECONDARY	3
SECONDARY DOT	1

PCB Land Pattern

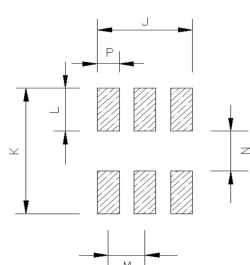

SLMB-TC1-1T

Features

- usable over 0.4-500 MHz
- excellent amplitude unbalance, 0.1 dB typ. and phase unbalance, 2 deg typ. in 1 dB bandwidth
- good return loss
- plastic base with leads
- aqueous washable

Applications

- VHF/UHF receivers/transmitters
- push-pull amplifiers

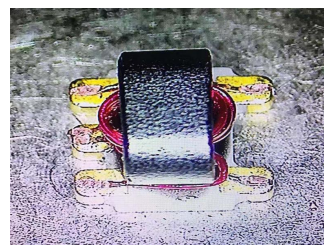

50Ω 0.4 to 500 MHz

Transformer Electrical Specifications

Ω RATIO	FREQUENCY (MHz)	INSERTION LOSS*	PHASE UNBALANCE (Deg.) Typ.	AMPLITUDE UNBALANCE (dB) Typ.
1	0.4-500	0.4-500 1dB	7	1

* Insertion Loss is referenced to mid-band loss, 0.3 dB typ.

Config. A

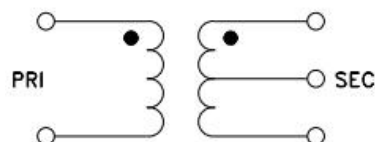

Typical Performance Data

FREQUENCY (MHz)	INSERTION LOSS (dB)	INPUT R. LOSS (dB)	AMPLITUDE UNBALANCE (dB)	PHASE UNBALANCE (Deg.)
0.30	0.88	15.46	0.06	0.03
1.00	0.57	21.01	0.04	0.05
5.00	0.33	27.35	0.02	0.01
10.00	0.32	28.55	0.02	0.15
50.00	0.40	23.46	0.02	0.63
100.00	0.51	18.34	0.06	1.24
200.00	0.78	13.01	0.21	2.57
300.00	1.10	10.06	0.47	3.99
400.00	1.46	8.16	0.82	5.66
500.00	1.84	6.90	1.26	7.50

Maximum Ratings

Operating Temperature -20°C to 85°C

Storage Temperature -55°C to 100°C

RF Power 0.5W

DC Current 30mA

Permanent damage may occur if any of these limits are exceeded.

Outline Drawing

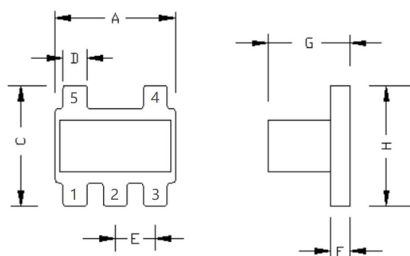

Outline Dimensions (mm)

A	3.81	N	-
B	-	M	1.27
C	3.81	P	0.76
D	0.76		
E	1.27		
F	0.61		
G	2.61		
H	3.81		
J	-		
K	4.81		
L	1.30		
WT	0.1		

Pin Connections

- PRIMARY 5
- SECONDARY CT 2
- PRIMARY DOT 4
- SECONDARY 1
- SECONDARY DOT 3

PCB Land Pattern

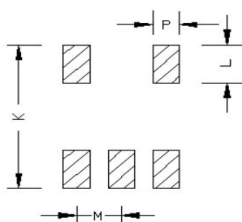

SLMB-TCM2-43X

Features

- wide bandwidth 10 to 4000 MHz
- balanced transmission line
- excellent return loss
- aqueous washable

Applications

- PCS
- wideband push-pull amplifiers
- cellular

Electrical Schematic

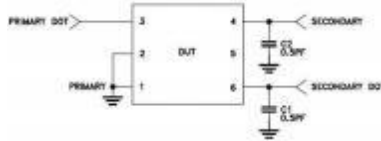

50Ω 10 to 4000 MHz

Electrical Specifications at 25°C

Parameter	Frequency(MHz)	Min.	Typ.	Max.	Unit
Impedance Ratio	-	-	2	-	-
Frequency Range	-	10	-	4000	Mhz
Insertion Loss*	10-4000	-	1.3	3.0	dB
Amplitude Unbalance	10-4000	-	0.5	-	dB
Phase Unbalance†	10-4000	-	7	-	Degree

Maximum Ratings

Operating Temperature	-40°C to 85°C
Storage Temperature	-55°C to 100°C
RF Power Input*	0.4W
DC Current	30mA

Permanent damage may occur if any of these limits are exceeded.

Pid Connections

PRIMARY DOT	3
PRIMARY	1,2
SECONDARY DOT	6
SECONDARY	4
GND	1,2
NOT USED	5

Typical Performance Data

(TEST CONDITIONS: INPUT POWER = 0dBm @Temperature = +25°C)

FREQUENCY (MHz)	INSERTION LOSS (dB)	INPUT R. LOSS (dB)	AMPLITUDE UNBALANCE (dB)	PHASE UNBALANCE (Deg.)
10	1.88	15.46	0.08	0.74
100	1.76	15.22	0.03	1.07
500	1.61	14.98	0.24	4.40
1000	1.35	15.87	0.32	5.96
1500	1.17	17.86	0.09	6.73
2000	1.09	21.30	0.23	7.01
2500	1.11	24.93	0.52	7.71
3000	1.17	25.06	0.82	6.95
3500	1.26	23.10	0.79	5.04
4000	1.55	16.24	0.81	3.16

Outline Drawing

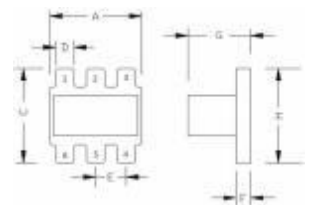

PCB Land Pattern

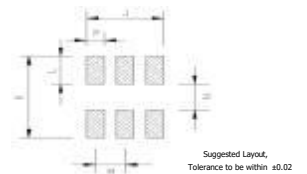

Outline Dimensions, Unit (mm)

A	3.81	C	3.81	D	0.76
E	1.27	F	0.61	G	2.61
H	3.81	J	3.30	K	4.83
L	1.65	N	1.53	M	1.27
WT			0.15g	P	0.76

Suggested PCB Layout

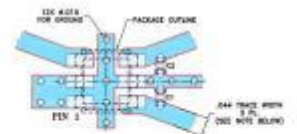

COMPONENT SIZE: 0.5 x 0.5 (mm)

NOTE: 1. TRACE WIDTH IS SHOWN FOR ROSEBUD ROSEBUD WITH SELECTIVE THICKNESS 80/170 μm. OTHER MATERIALS TRACE WIDTH MAY NEED TO BE ADJUSTED. FOR OTHER MATERIALS TRACE WIDTH MAY NEED TO BE ADJUSTED.
 2. BOTTOM SIDE OF THE PCB IS CONDUCTIVE GROUND PLANE.
 3. CHIP COMPONENT FOOT PRINTS SHOWN FOR REFERENCE. FOR COMPONENT VALUES REFER TO 96-001A.
 4. DIMENSIONS FOR COPPER LAYOUT WITH SOLDER (SOLDER MASK OVER BARE COPPER)

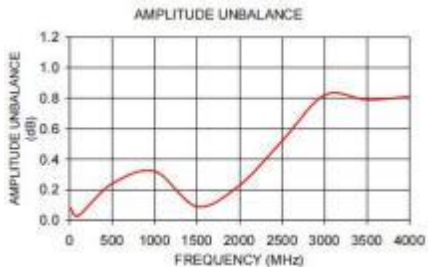
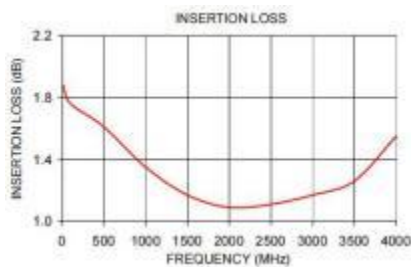

SLMB-TC1-1-13M

Features

- wideband, 4.5 to 3000 MHz
- balanced transmission line
- good return loss
- excellent amplitude unbalance, 0.5 dB typ. and phase unbalance, 2 deg typ. in 1 dB bandwidth
- plastic base with leads
- aqueous washable

Applications

- balanced to unbalanced transformation
- push-pull amplifiers
- PCS/DCS
- MMDS



50Ω 4.5 to 3000 MHz

Transformer Electrical Specifications

Ω RATIO	FREQUENCY (MHz)	INSERTION LOSS*	PHASE UNBALANCE (Deg.) Typ.	AMPLITUDE UNBALANCE (dB) Typ.
1	4.5-3000	4.5-3000 1dB	5	0.5

* Insertion Loss is referenced to mid-band loss, 0.3 dB typ.

Config. G

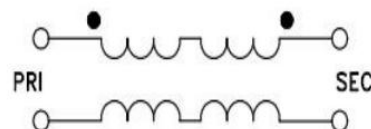

Typical Performance Data

FREQUENCY (MHz)	INSERTION LOSS (dB)	INPUT R. LOSS (dB)	AMPLITUDE UNBALANCE (dB)	PHASE UNBALANCE (Deg.)
4.50	0.18	31.52	0.69	3.81
10.00	0.18	34.60	0.56	1.78
50.00	0.19	33.50	0.56	0.11
100.00	0.24	29.68	0.55	0.19
500.00	0.46	19.52	0.45	0.81
1000.00	0.68	16.22	0.14	1.59
1500.00	0.90	15.89	0.29	0.89
2000.00	1.11	16.97	0.71	1.28
2500.00	1.62	12.88	0.78	5.79
3000.00	3.02	6.79	0.49	12.32

Maximum Ratings

Operating Temperature	-20°C to 85°C
Storage Temperature	-55°C to 100°C
RF Power	0.5W
DC Current	30mA
Permanent damage may occur if any of these limits are exceeded.	

Outline Drawing

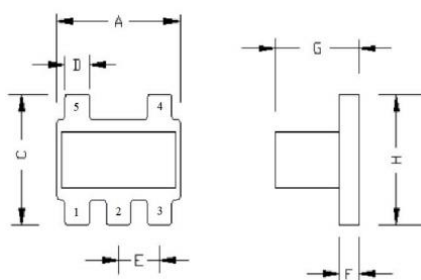

Outline Dimensions (mm)

A	3.81	N	-
B	-	M	1.27
C	3.81	P	0.76
D	0.76	H	3.81
E	1.27	J	-
F	0.61	K	4.81
G	2.61	L	1.3
WT	0.05		

Pin Connections

PRIMARY	5
NC	2
PRIMARY DOT	4
SECONDARY	1
SECONDARY DOT	3

PCB Land Pattern

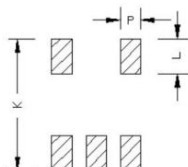

SLMB-JTX-4-10T

Features

- excellent return loss, 22 dB typ .
- excellent amplitude unbalance, 0.2 dB typ. and phase unbalance, 2 deg. typ. in 1 dB bandwidth

Applications

- impedance matching
- balanced amplifiers

Electrical Specifications

Ω RATIO (Secondary/Primary)	FREQUENCY (MHz)	INSERTION LOSS*	PHASE UNBALANCE (Deg.) Typ.	AMPLITUDE UNBALANCE (dB)Typ.
4	50~1000	1.0	2.0	0.2

Typical Performance Data

FREQUENCY (MHz)	INSERTION LOSS (dB)	INPUT R. LOSS (dB)	AMPLITUDE UNBALANCE (dB)	PHASE UNBALANCE (Deg.)
50.00	1.42	20.84	0.06	0.35
130.00	1.38	22.75	0.02	1.77
210.00	1.40	20.52	0.09	2.44
300.00	1.43	18.71	0.16	2.76
425.00	1.48	17.75	0.22	2.82
550.00	1.52	18.42	0.26	2.61
675.00	1.54	20.24	0.25	2.16
800.00	1.57	24.59	0.18	1.69
925.00	1.65	32.84	0.13	1.23
1000.00	1.73	24.64	0.22	1.10

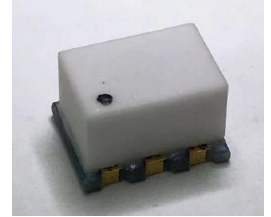

50Ω 50 to 1000 MHz

Config. A

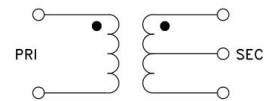

Pin Connections

PRIMARY DOT	3
PRIMARY	1
SECONDARY DOT	6
SECONDARY	4
SECONDARY CT	5
NOT USED	2

Outline Drawing

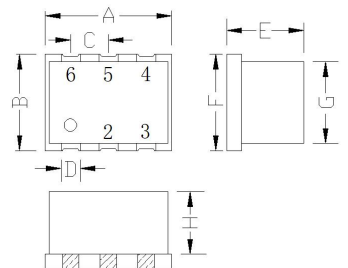

PCB Land Pattern

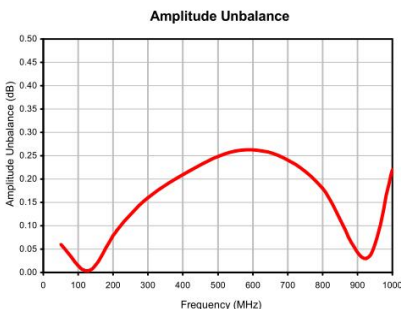
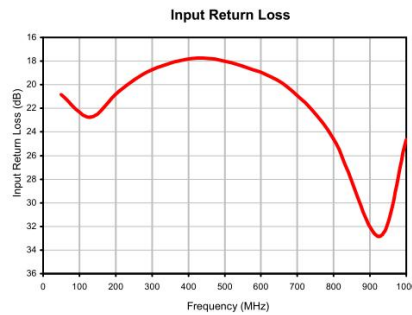
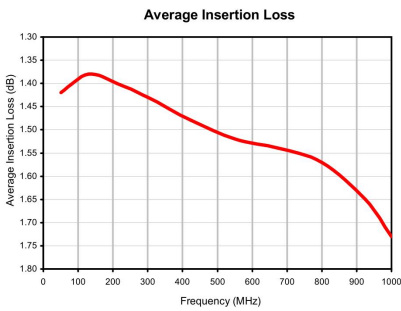
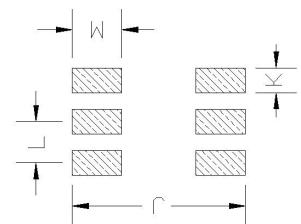

Maximum Ratings

Operating Temperature	-20°C to 85°C
Storage Temperature	-55°C to 100°C
RF Power	0.25W max.
DC Current	30mA

Permanent damage may occur if any of these limits are exceeded.

Outline Dimensions : Unit (mm)			
A	8.70	J	8.00
B	6.50	K	1.50
C	2.54	G	5.50
D	1.30	H	4.30
E	5.40	L	2.54
F	6.50	M	2.00
WT	0.5g		

50 Ω 700 to 1400MHz 1:2 Ratio

Ver. A

2023.05.26

Maximum Rating

Operating Temperature	-40°C~+85°C
Storage Temperature	-55°C~+100°C
RF Input Power	5W max at 25°C

Pin Connections

PRIMARY DOT	4
PRIMARY (GND)	2,5
SECONDARY DOT	1
SECONDARY	6
NO CONNECTION	3

Outline Drawing

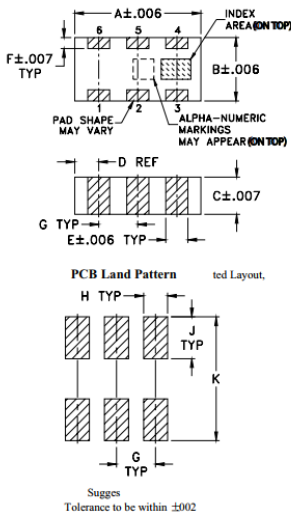

Outline Dimensions (inch/mm)

A	B	C	D	E	F
.126	.063	.035	.024	.022	.011
3.20	1.60	0.89	0.61	0.56	0.28
G	H	J	K	wt	
.039	.024	.042	.123	grams	
0.99	0.61	1.07	3.12	.020	

Recommended PC Board Pattern

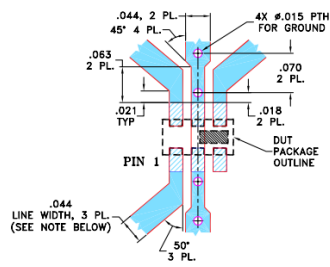

- NOTE:
- TRACE WIDTH IS SHOWN FOR ROGERS RO4350B WITH DIELECTRIC THICKNESS .020" ± .0015". COPPER: 1/2 OZ. EACH SIDE. FOR OTHER MATERIALS TRACE WIDTH MAY NEED TO BE MODIFIED.
 - BOTTOM SIDE OF THE PCB IS CONTINUOUS GROUND PLANE. DENOTES PCB COPPER LAYOUT WITH SMOBC (SOLDER MASK OVER BARE COPPER). DENOTES COPPER LAND PATTERN FREE OF SOLDER MASK

* Line width should be designed to match 50 characteristic impedance, depending on PCB material and thickness.

Features

- Multilayer LTCC (Low Temperature Cofired Ceramics) Technology.
- Miniatured Size L*W*H: 3.2x1.6x0.95mm
- Low Insertion Loss reduces power consumption
- Low inband Amplitude and Phase imbalance
- Single ended 50 ohm differential 100 ohm
- LTCC Structure



RoHS Compliant

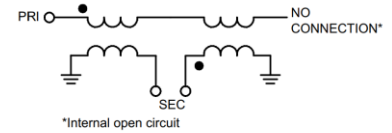

Functional Schematic

Application

- Applied to GSM、TDMA、PDC、WAN、TACS、AMPS、NAMPS navigation.

Electrical Specifications at 25°C

Parameter	Frequency (MHz)	MIN	Typ.	MAX	Unit
Impedance Ratio (Secondary/Primary)			2		
Frequency Range		700		1400	MHz
Insertion Loss	700-1400	-	0.9	-	dB
	800-1000	-	0.7	-	
Amplitude Unbalance	700-1400	-	0.8	-	dB
	800-1000	-	0.35	-	
Phase Unbalance	700-1400	-	8.0	-	Degree
	800-1000	-	8.0	-	

Frequency characteristics

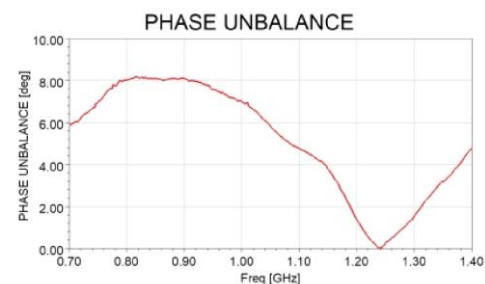
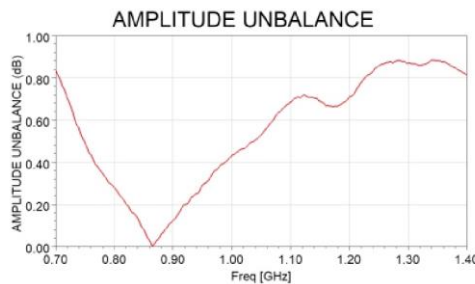
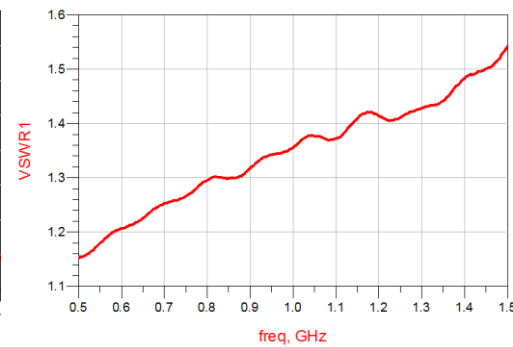
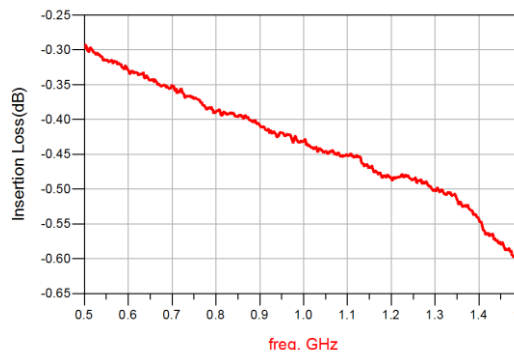

Notes

- The specifications are tested at 25°C±5°C, relative humidity 55~75%.
- Other quality and characteristic not specify in this datasheet. Please contact us for detail requirements.

Surface Mount RF Transformer(50 Ω , 9~625MHz) RF-2C-625

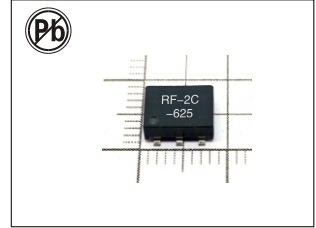

FEATURES:

- excellent return loss, 25 dB typ.
- excellent amplitude unbalance, 0.2 dB typ. phase unbalance, 1 deg. typ. in 1 dB bandwidth
- high RF power up to 1 watt
- aqueous washable

APPLICATIONS:

- impedance matching
- baluns

PACKAGING:

- 7" Reel: 20, 50, 100, 200,500Devices/Reel
- 13" Reel: 500, 1000 Devices/Reel

ELECTRICAL CHARACTERISTICS:

Impedance ratio (Ω) Sec : Pri	Frequency range (MHz)	Insertion loss(MHz)			Phase unbalance (Deg.)Typ.		Amplitude unbalance (dB)Typ.	
		3dB	2dB	1dB	1dB bandwidth	2dB bandwidth	1dB bandwidth	2dB bandwidth
4	9~625	9~625	10~550	14~500	1	3	0.2	0.3

Note: Insertion Loss is referenced to mid-band loss, 0.55 dB typ.

TECHNICAL INFORMATION & PHYSICAL CHARACTERISTICS:

Dimensions(mm)

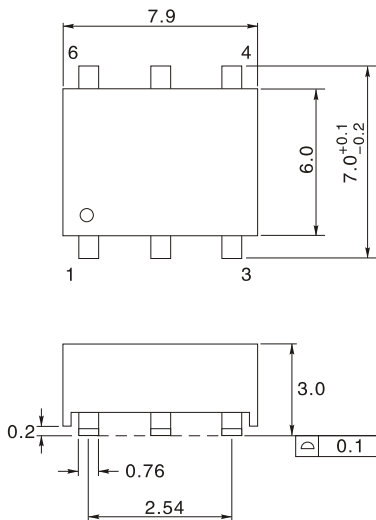

PCB Land pattern

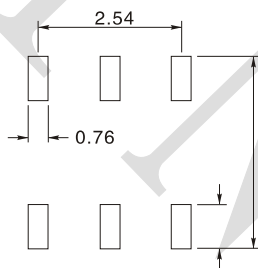

Schematic

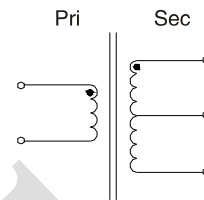

Pin Connections

PRIMARY DOT	3
PRIMARY	1
SECONDARY DOT	4
SECONDARY	6
SECONDARY CT	5
NOT USED	2

Notes:

- Operating Temperature -20°C to 85°C
- Storage Temperature -55°C to 100°C
- RF Power 1W
- DC Current 30mA

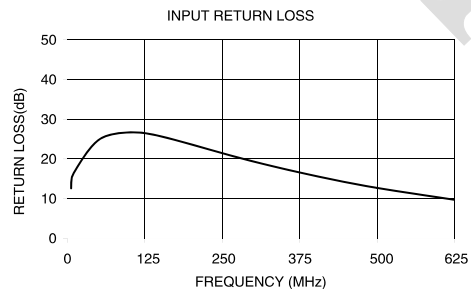

Surface Mount RF Transformer(50 Ω , 2~775MHz) RF-2C-775

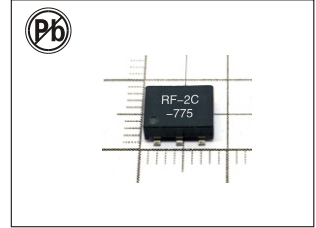

FEATURES:

- excellent return loss, 20 dB typ. in dB bandwidth
- excellent amplitude unbalance, 0.1 dB typ. and phase unbalance, 1 deg. typ. in 1 dB bandwidth
- aqueous washable

APPLICATIONS:

- impedance matching
- baluns

PACKAGING:

- 7" Reel: 20, 50, 100, 200,500Devices/Reel
- 13" Reel: 500, 1000 Devices/Reel

ELECTRICAL CHARACTERISTICS:

Impedance ratio (Ω) Sec : Pri	Frequency range (MHz)	Insertion loss(MHz)			Phase unbalance (Deg.)Typ.		Amplitude unbalance (dB)Typ.	
		3dB	2dB	1dB	1dB bandwidth	2dB bandwidth	1dB bandwidth	2dB bandwidth
4	2~775	2~775	3~600	6~250	1	3	0.1	0.3

Note:Insertion Loss is referenced to mid-band loss, 0.8 dB typ.

TECHNICAL INFORMATION & PHYSICAL CHARACTERISTICS:

Dimensions(mm)

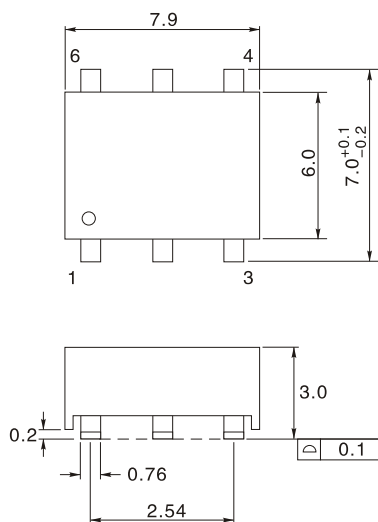

PCB Land pattern

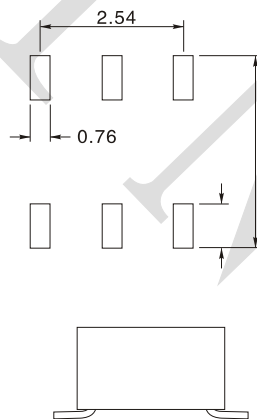

Schematic

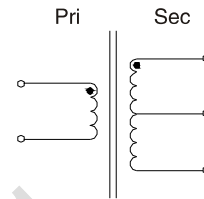

Pin Connections

PRIMARY DOT	3
PRIMARY	1
SECONDARY DOT	4
SECONDARY	6
SECONARY CT	5
NOT USED	2

Notes:

- Operating Temperature -20°C to 85°C
- Storage Temperature -55°C to 100°C
- RF Power0.25W
- DC Current30mA

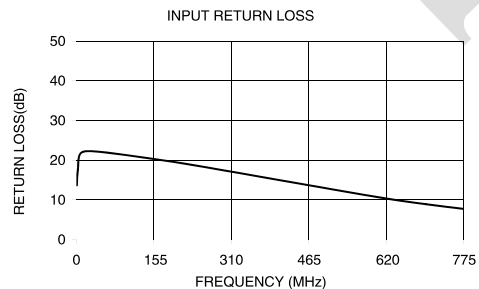
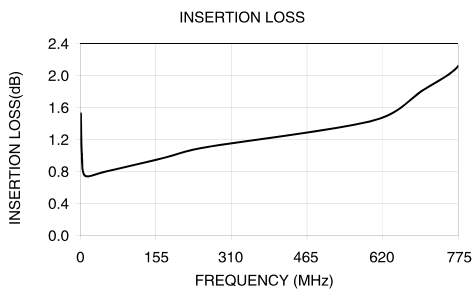

Surface Mount RF Transformer(50 Ω , 20~1200MHz) RF-2C-1200

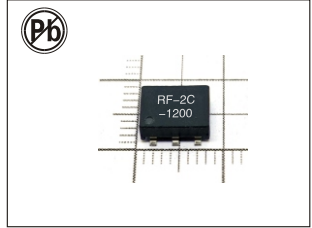

FEATURES:

- wideband, 20 to 1200 MHz
- balanced transmission line
- excellent amplitude unbalance, 0.3 dB typ. and phase unbalance, 3 deg. typ. in 1 dB bandwidth
- RF power, 2W
- aqueous washable

APPLICATIONS:

- impedance matching
- baluns
- balanced amplifier
- cellular
- VHF

PACKAGING:

- 7" Reel: 20, 50, 100, 200,500Devices/Reel
- 13" Reel: 500, 1000 Devices/Reel

ELECTRICAL CHARACTERISTICS:

Impedance ratio (Ω) Sec : Pri	Frequency range (MHz)	Insertion loss(MHz)			Phase unbalance (Deg.)Typ.		Amplitude unbalance (dB)Typ.	
		3dB	2dB	1dB	1dB bandwidth	2dB bandwidth	1dB bandwidth	2dB bandwidth
1	20~1200	---	20~1200	50~1000	3	4	0.3	0.5

Note:Insertion Loss is referenced to mid-band loss, 0.6 dB typ.

TECHNICAL INFORMATION & PHYSICAL CHARACTERISTICS:

Dimensions(mm)

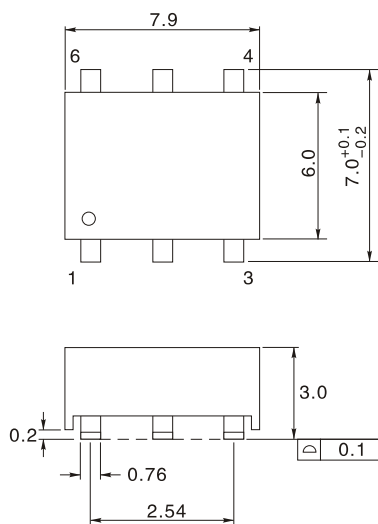

PCB Land pattern

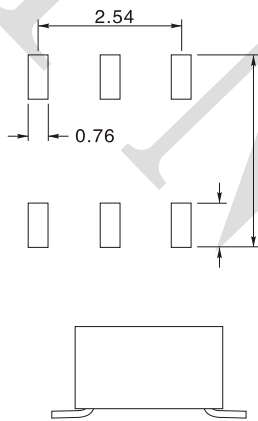

Schematic

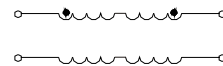

Pin Connections

PRIMARY DOT	1
PRIMARY	3
SECONDARY DOT	6
SECONDARY	4
NOT USED	2,5

Notes:

- Operating Temperature -20°C to 85°C
- Storage Temperature -55°C to 100°C
- RF Power2W
- DC Current30mA

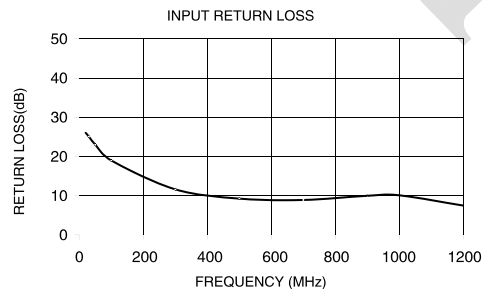

BALUN

Multilayer Chip Type

Small Size • Low Loss • High Reliability

Simplify Circuit Design & Tuning



PHONE



PDA

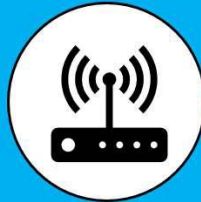

RF DEVICE

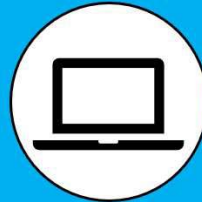

NOTEBOOK

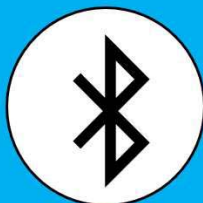

BLUETOOTH

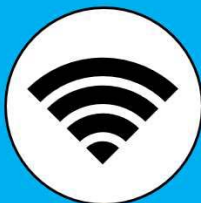

WLAN



GPS



DVD

BALUN

Product Structure

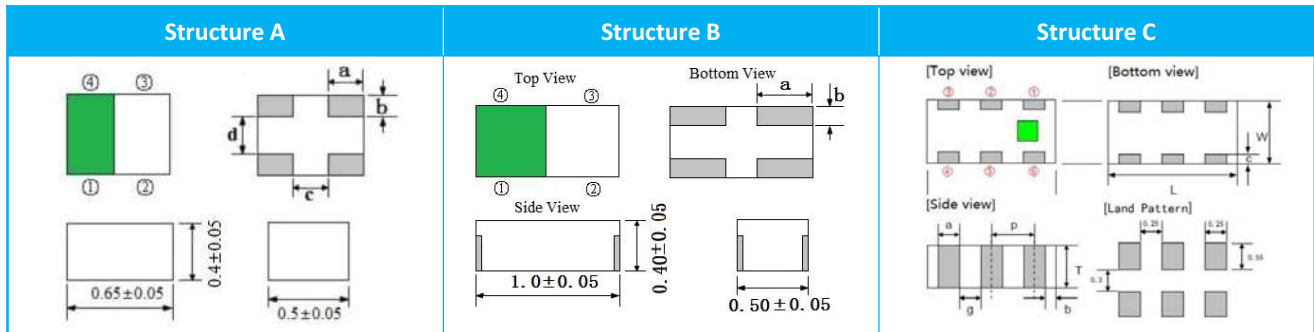



Pin Description & Dimension

Shinohm P/N	Structure	Size (mm)			Pin No. & Description					
		L	W	T	1	2	3	4	5	6
MGMB0605H2-0790B26	A	0.6±0.05	0.5±0.05	0.4±0.05	GND	Unbalance	Balance	Balance		
MGMB0605H2-1900B25	A	0.6±0.05	0.5±0.05	0.4±0.05	GND	Unbalance	Balance	Balance		
MGMB0605H2-2500B19	A	0.6±0.05	0.5±0.05	0.4±0.05	GND	Unbalance	Balance	Balance		
MGMB15H2-1900B23	B	1.0±0.05	0.5±0.05	0.4±0.05	GND	Unbalance	Balance	Balance		
MGMB15H2-2450B18	B	1.0±0.05	0.5±0.05	0.4±0.05	GND	Unbalance	Balance	Balance		
MGMB18H1-1686B27	C	1.6±0.1	0.8±0.1	0.6±0.1	Unbalance	GND	Balance	Balance	GND	NC
MGMB18H1-1700B31	C	1.6±0.1	0.8±0.1	0.7 Max.	Unbalance	GND	Balance	Balance	GND	NC
MGMB18H1-2450B12	C	1.6±0.1	0.8±0.1	0.45±0.1	Unbalance	GND	Balance	Balance	GND	NC
MGMB18H2-1700B32	C	1.6±0.2	0.8±0.2	0.6±0.1	Unbalance	GND	Balance	Balance	GND	NC
MGMB18H2-4600B30	C	1.6±0.1	0.8±0.1	0.7 Max.	Unbalance	GND	Balance	Balance	GND	NC
MGMB18H4-2450B20	C	1.6±0.1	0.8±0.1	0.45 Max.	Unbalance	GND	GND	Balance	GND	Balance
MGMB21H2-2350B38	C	2.0±0.2	1.25±0.2	0.65±0.1	Unbalance	GND	Balance	Balance	GND	NC

BALUN

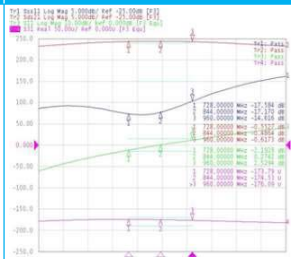
Electrical Characteristics

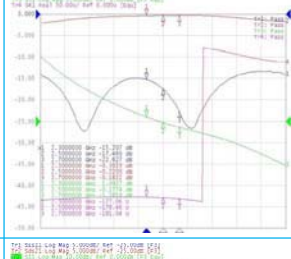
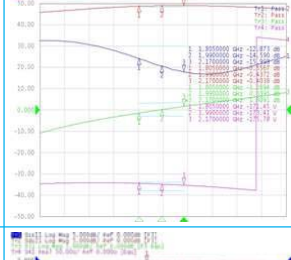
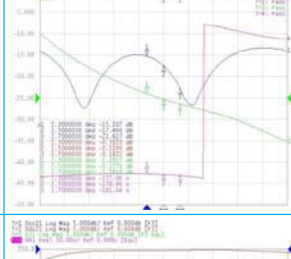
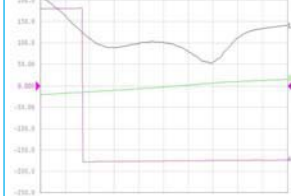
Shinohm P/N	Freq. Range (MHz)	I. L. (dB/Max.)	Impedance (Ω)		VSWR (in BW)	Amplitude Diff. (dB)	Phase Diff. (Deg.)	Electrical Characteristics
			Unbalance	Balance				
MGMB0605H2-0790B26	728~960	0.95	50	100	≤ 2.0	≤ 4.8	180 ± 10	
MGMB0605H2-1900B25	1805~2170	0.6	50	100	≤ 2.0	≤ 2.5	180 ± 10	
MGMB0605H2-2500B19	2300~2690	0.6	50	100	≤ 2.0	≤ 2.5	180 ± 10	
MGMB15H2-1900B23	1805~2170	0.6	50	100	≤ 2.0	≤ 2.2	180 ± 10	
MGMB15H2-2450B18	2300~2690	0.6	50	100	≤ 2.0	≤ 2.5	180 ± 10	
MGMB18H1-1686B27	673~2700	1.7 (@+25°C) 2.0 (@-45~+85°C)	50	100	≤ 2.45	≤ 1.5	180 ± 17	

BALUN

Electrical Characteristics

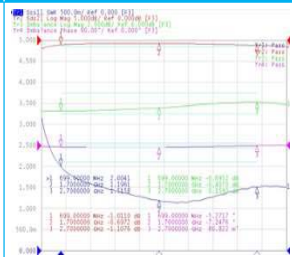
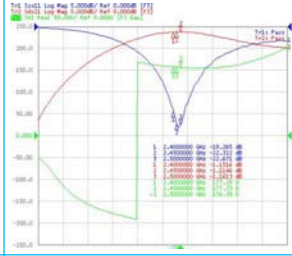
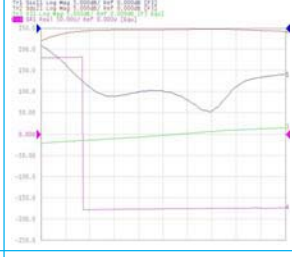
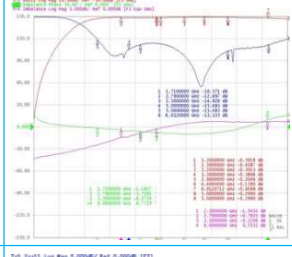
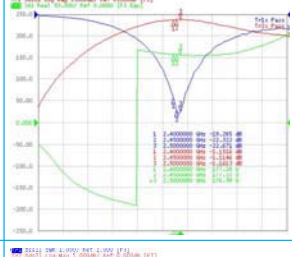
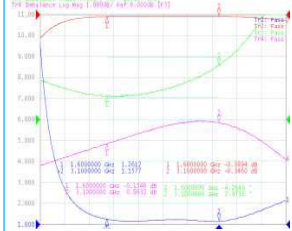
Shinohm P/N	Freq. Range (MHz)	I. L. (dB/Max.)	Impedance (Ω)		VSWR (in BW)	Amplitude Diff. (dB)	Phase Diff. (Deg.)	Electrical Characteristics
			Unbalance	Balance				
MGMB18H1-1700B31	699~2700	1.6	50	50	≤ 2.1	≤ 1.0	180 ± 10	
MGMB18H1-2450B12	2400~2500	1.2	50	50	≤ 2.0	≤ 2.0	180 ± 10	
MGMB18H2-1700B32	599~2800	1.7 (@+25°C) 1.9 (@-45~+85°C)	50	100	≤ 2.0	≤ 1.0	180 ± 10	
MGMB18H2-4600B30	3200~6000	1.0 (@+25°C) 1.2 (@-40~+105°C)	50	100	≤ 2.0	≤ 1.2	180 ± 10	
MGMB18H4-2450B20	2400~2500	1.3	50	Matched to AR6003	≤ 2.0	≤ 2.5	180 ± 10	
MGMB21H2-2350B38	1600~3100	1	50	100	≤ 2.0	≤ 1.0	180 ± 10	

客户 CUSTOMER: _____

日期 DATE: _____

SPECIFICATION

产品名称 PRODUCT NAME: Integrated Balun-Filter

贵司料号 YOUR PART NO.:

敝司料号 OUR PART NO.: SLMB18H2-1700B32

版本号 VERSION.: V1.0

接受 RECEPTION THE SPECIFICATION HAS BEEN ACCEPTED. 日期: DATE: 公司: COMPANY:		
批准 CFMD	审核 CHKD	接收 RCVD

CFMD. 批准	CHKD. 审核	DSGD. 担当

目录 CATALOG

1 适用范围 Scope	4
2 品名构成 Product Identification	4
3 形状和尺寸 Appearance and Dimensions	4
4 测试条件 Testing Conditions	5
5 电气性能 Electrical Characteristics	5
6 信赖性试验 Reliable Performance.....	6
7 焊接条件 Recommended Soldering Conditions.....	8
8 包装 Packaging.....	9
9 装箱清单及标志 Packing documents and marking.....	10
10 保管 Storage.....	12

1 适用范围 Scope

Shinhom Microwave Balun SLMB series are designed to be used in WLAN、GSM、Bluetooth、DVD & cordless phones with low insertion loss and small size SMD chip design , which can simplify your complex tuning and circuit design .

Shinhom 微波阻抗转换器 SLMB 系列产品设计用于 WLAN、GSM、Bluetooth、DVD 和无绳电话机中，具有低的插入损耗和小体积 SMD 片式设计，能减少复杂的调校工作，可以简化电路设计。

2 品名构成 Product Identification

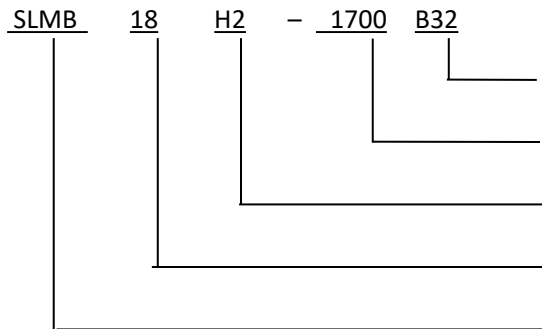

标准规格，编号 Normalizing Type: B32

中心频率 Center Frequency: 1700 MHz

阻抗转换/ Impedance Conversion: 50Ω : 100Ω

产品尺寸/Size: 1.6mm × 0.8 mm

叠层结构阻抗转换器: Multi-layer Balun

3 形状和尺寸 Appearance and Dimensions

Unit: mm

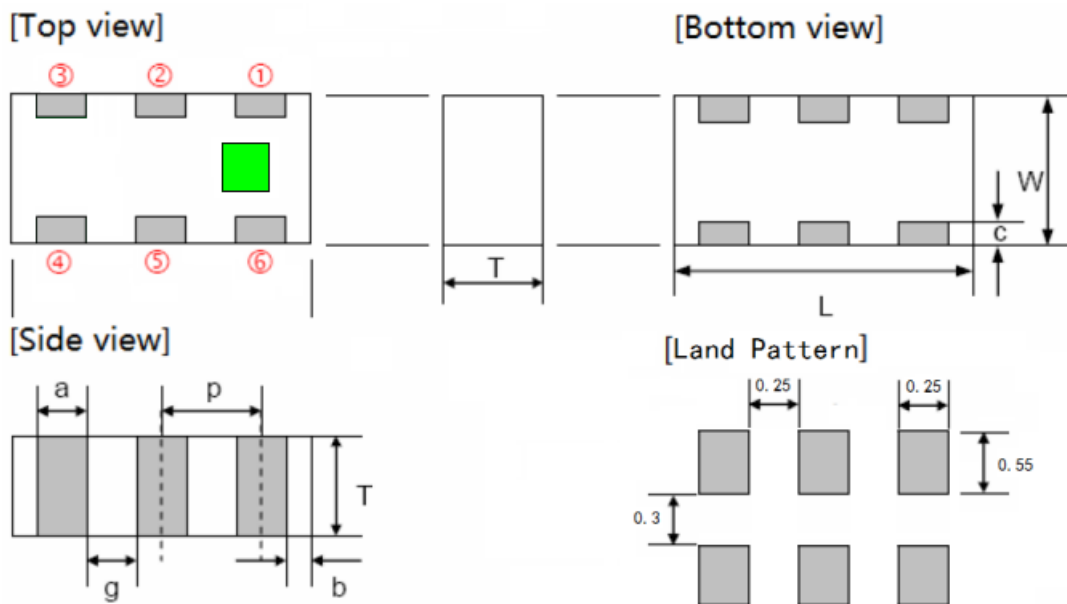

Dimensions

L	W	T	a	b	c	g	p
1.6 ± 0.1	0.8 ± 0.1	0.6 ± 0.1	0.2 ± 0.1	0.2 ± 0.1	0.15 ± 0.1	0.3 ± 0.1	0.5 ± 0.1

PIN Configuration

①	②	③	④	⑤	⑥
Unbalance Port (In)	GND	Balance Port (Out)	Balance Port (Out)	GND	NC

4 测试条件 Testing Conditions

除非另有规定，否则在以下条件下测试 <Unless otherwise specified>

温度 Temperature : Ordinary Temperature (5 to 35°C)

湿度 Humidity : Ordinary Humidity (25 to 85% RH)

大气压强 Atmospheric Pressure : 86 to 106 kPa

当对测量结果有疑问时<In case of doubt>

温度 Temperature : 20±2°C

湿度 Humidity : 60 to 75% RH

大气压强 Atmospheric Pressure : 86 to 106 kPa

5 电气性能 Electrical Characteristics

操作温度范围 Operating Temperature Range : -40 to +85°C

保存温度范围 Storage Temperature Range : -40 to +85°C

Frequency Range (MHZ) 频率范围	Insertion Loss(dB) 插入损耗	Impedance (Ω) 阻抗	V.S.W.R (in BW) 驻波比	Amplitude difference (dB) 幅度差	Phase difference (Deg)相位差
599-699	≤1.7 @+25°C ≤1.9 @-45~+85°C	50: 100	≤2.0	≤1.0	180±10
699-2700	≤1.3 @+25°C ≤1.5 @-45~+85°C				
2700-2800	≤1.7 @+25°C ≤1.9 @-45~+85°C				

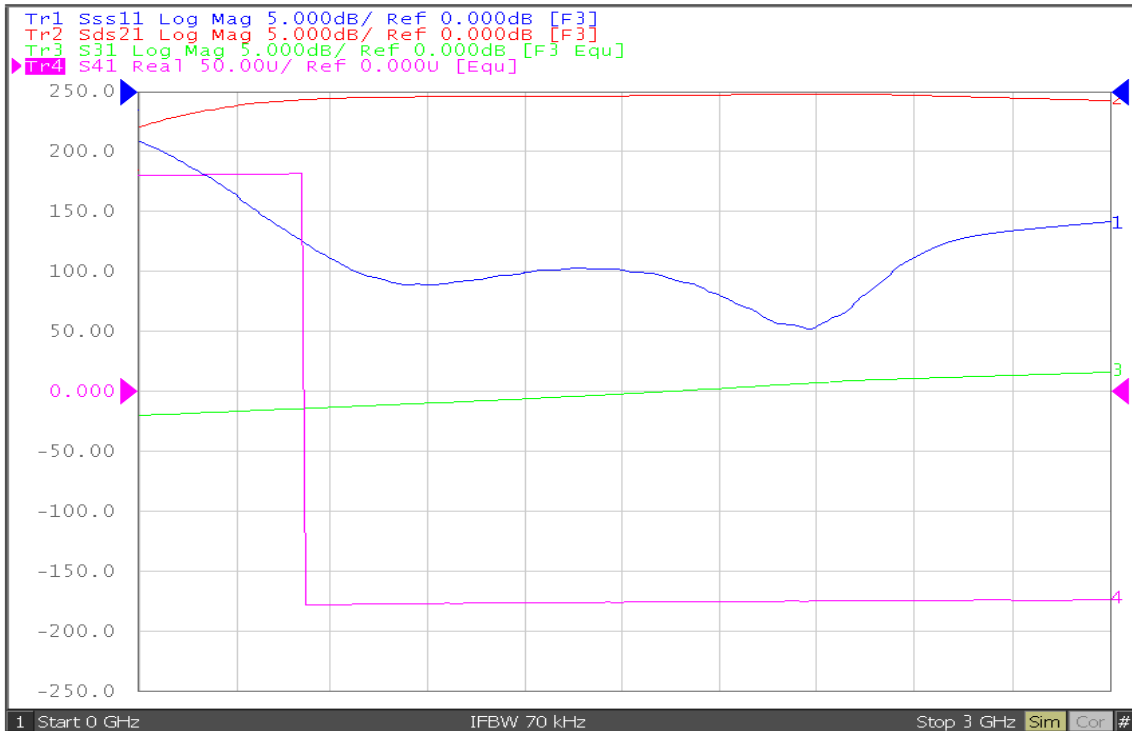

6 信赖性试验 Reliable Performance

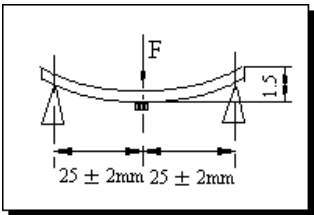
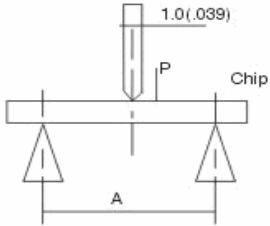
NO.	Item	Specifications	Test Methods						
6-1	Solder-Ability 可焊性	More than 90% of termination should be covered with new solder. 端电极焊锡覆盖率为90%以上。	焊锡 Solder: 无铅焊锡						
			焊锡温度 Temperature: 255°C+5°C/-0°C						
			助焊剂 Flux: 松香 rosin						
			浸渍时间 Duration: 5±0.5s						
6-2	Leaching Resistance 耐焊性	More than 75% of termination should be covered with new solder. 端电极焊锡覆盖率为75%以上	焊锡 Solder: 无铅焊锡						
			焊锡温度 Temperature: 270°C+2°C/-0°C						
			助焊剂 Flux: 松香 rosin						
			浸渍时间 Duration: 10±0.5s						
6-3	Terminal Strength 端头强度	The terminal and body should be no damage 端头和瓷体不应见损伤	The device should not be broken after tensile force of 1.0kg is slowly applied to pull a lead pin of the fixed device in the lead axis direction for 10±1 seconds. 在产品电极端子上或表面上应能承受 1kg 垂直拉力 10±1 秒						
6-4	Bending Strength 弯曲试验	No mechanical damage should be noticed 不应见机械损伤	Weld the product to the center part of the PCB with the thickness 1.6±0.2mm as the illustration shows, and keep exerting force arrow-ward on it at speed of: 1mm/S, and hold for 5±1S at the position of 1.5mm bending distance, so far, any peeling off of the product metal coating should not be detected. 将产品按图焊在 1.6±0.2mm 的 PCB 板中间, 由箭头方向施力 1mm/S, 弯曲距离 1.5mm, 保持 5±1S, 产品金属层无脱落。 						
6-5	Body Strength 抗压强度	The body should not be damaged 瓷体不应见损伤	Applied specified pull strength in axial direction 在轴向上施加压力如下: <table border="1" data-bbox="804 1691 1062 1794"> <thead> <tr> <th>Size</th> <th>A/mm</th> <th>P/N</th> </tr> </thead> <tbody> <tr> <td>2012</td> <td>1.4</td> <td>9.8</td> </tr> </tbody> </table> 	Size	A/mm	P/N	2012	1.4	9.8
Size	A/mm	P/N							
2012	1.4	9.8							

NO.	Item	Specifications	Test Methods
6-6	Drop 跌落	Post Environmental Tolerance (环境试验后允许附加误差) 1 Center Frequency 中心频率 fo: ±5.0 MHz; 2 Insertion Loss 插入衰减: ±0.5 dB; 3 Band Width 通带宽度: ±5.0 MHz 4 V.S.W.R (in BW) 驻波比: ±0.2 5 Attenuation 阻带衰耗: ±2.0 dB 6 Phase difference 相位差: ±5 Deg	Drop 10 times on a concrete floor from a height of 1m. 从距混凝土地面 1m 高度自由落下, 重复 3 次。
6-7	Vibration 振动		频率 Frequency: 10 to 55Hz 振幅 Amplitude: 1.5mm 方向及时间 Direction and time: X, Y and Z directions for 2 hours each.
6-8	Humidity resistance 耐潮湿		a. 试验条件 Test condition 温度 Temp.: 60±2℃ 湿度 Humidity: 90%~95% 试验时间 Test time: 96±2 h b. 测量条件 Measurement method: 试验后常温常湿环境中放置 (24±2) 小时后测量。 The component should be stabilized at normal condition for (24±2) hours before test.
6-9	High temperature resistance 耐高温		a. 试验条件 Test condition 施加额定电流 Applied rated current. 温度 Temp.: + 85±2℃ 试验时间 Test time: 96±2 h b. 测量条件 Measurement method: 试验后常温常湿环境中放置 (24±2) 小时后测量。 The component should be stabilized at normal condition for (24±2) hours before test.
6-10	Low temperature resistance 耐低温		a. 试验条件 Test condition 温度 Temp.: -40±2℃ 试验时间 Test time: 96±2 h b. 测量条件 Measurement method: 试验后常温常湿环境中放置 (24±2) 小时后测量。 The component should be stabilized at normal condition for (24±2) hours before test.
6-11	Thermal shock (Temperature cycle) 热冲击 (温度循环)		a. 试验条件 Test condition 1) 温度 Temp.: -40℃, 时间 time: 30±3min 2) 温度 Temp.: +85℃, 时间 time: 30±3min 5 cycles b. 测量条件 Measurement method: 试验后常温常湿环境中放置 (24±2) 小时后测量。 The component should be stabilized at normal condition for (24±2) hours before test.

7 焊接条件 Recommended Soldering Conditions

产品可用于回流焊

Product can be applied to reflow soldering.

(1) 焊剂 Flux, Solder

① 使用松香助焊剂，禁止使用卤化物含量超过 0.2wt% 的强酸性助焊剂。

Use rosin-based flux. Don't use highly acidic flux with halide content exceeding 0.2wt% (chlorine conversion value).

② 使用纯锡焊料

Use Sn solder.

(2) 标准回流焊曲线 Standard soldering profile.

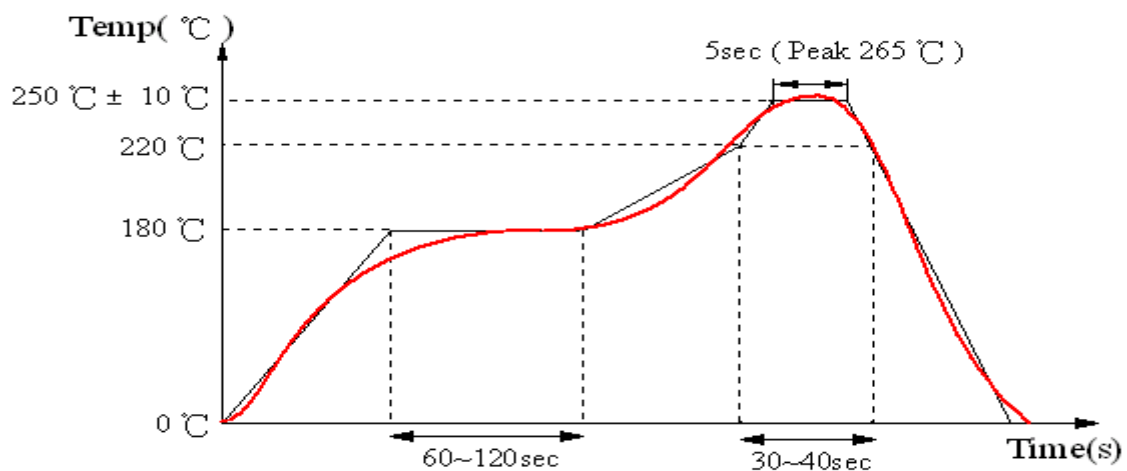

(3) 手工返工 Reworking with soldering iron

当使用电烙铁进行手工焊接时，以下条件必须严格遵守 The following conditions must be strictly followed when using a soldering iron.

预热 Pre-heating	150°C, 1 minute
尖端温度 Tip temperature	350°C max
输出功率 Soldering iron output	80w max
电烙铁头尖端尺寸 End of soldering iron	φ3mm max
焊接时间 Soldering time	3 seconds max

8 包装 Packaging

① 编带尺寸 Dimensions of Tape:

纸带 Paper carrier tape:

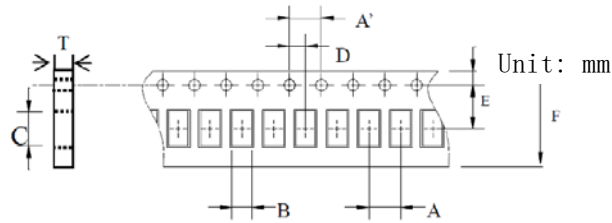

Type	A	A'	B	C	D	E	F	T	Tape Material
1608	4.0±0.1	4.0±0.1	1.1±0.1	1.9±0.1	2.0±0.1	3.5±0.1	8.0±0.1	0.75±0.05	Paper

② 带轮尺寸 Dimensions of Reel

Unit: mm

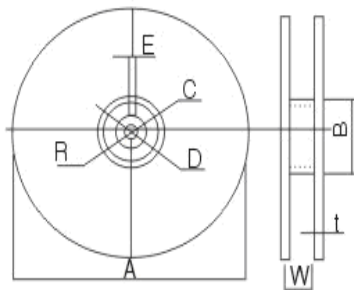

Reel material: PS (Polystyrene)

A	178±2
B	60±2
C	13.0±0.5
D	21.0±0.8
E	2.0±0.5
W	8.5±1.0
t	1.2±0.2
R	1.0±0.25

③ 编带抗拉强度 Pulling strength of tapes:

载带 Carrier tape	10N or more (1kgf or more)
上盖带 Cover tape	5N or more (1kgf or more)

④ 编带简图及拉伸方向 Taping figure and drawing direction:

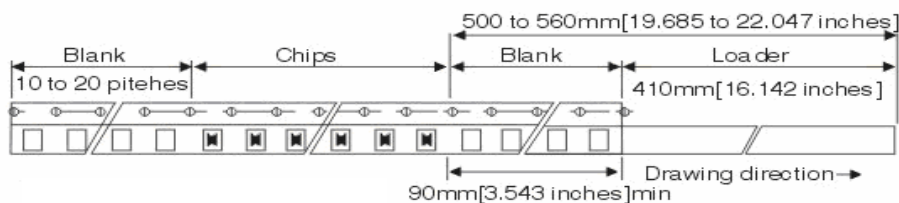
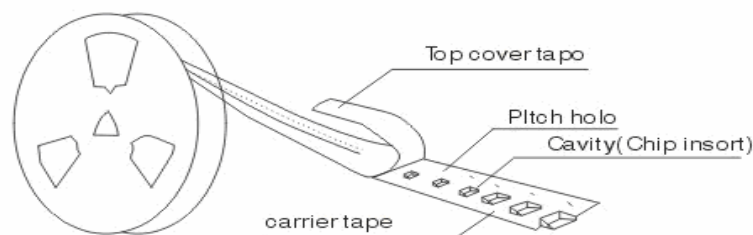

⑤ 盖带的剥离强度 Peeling strength of cover tape:

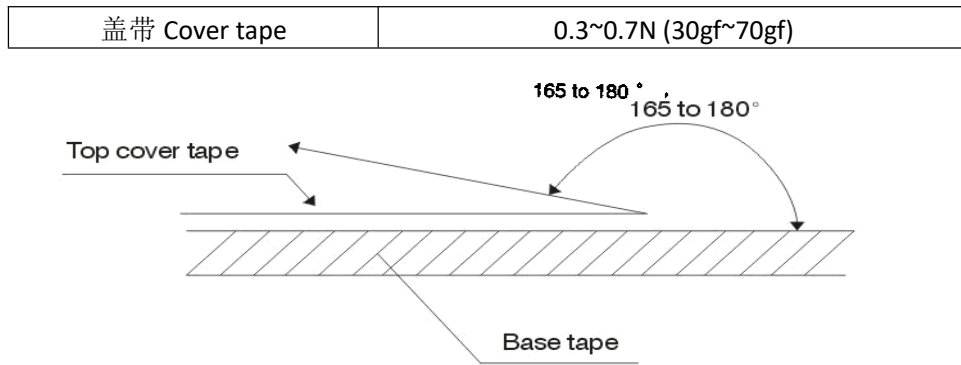

测试条件 Test condition:

- 1) 剥离角度 peel angle: 165°~180° vs. carrier tape.
- 2) 剥离速度 peel speed: 300mm/min±10%.

⑦ 包装数量 Packaging quantities: 4000 PCS / Reel

9 装箱清单及标志 Packing documents and marking

1. 包装文件 Packing documents

Packing includes the following:

- a. 装箱清单 Packing list.
- b. 合格证书 Certificate of compliance.

2. 盘上标记 Marking on reels:

- a 料号 Part No.
- b 生产批号 Lot number
- c 盘装数量 Quantity per reel
- d 检验员号 Inspector No.

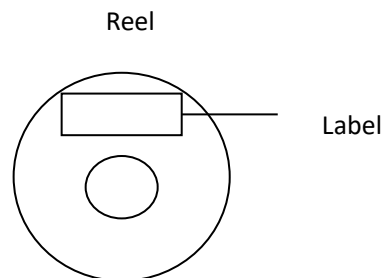

以上内容必须在标签上注明.All above shall be shown on marking label

标签如下所示: Marking label will be as following:

CUSTOMER:	P. O. NO	
CUSTOMER PART NO:	DATE CODE	LOT NO
PART NO:	QUANTITY	INSP. NO

检验合格后, 检验员在标签上盖上合格章。合格章如下所示: The eligible reels will be pressed a mark onto the surface. The mark will be as following:

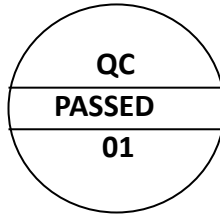

3. 内包装盒标记: Marking on inner box

- a. 型号 Part No.
- b. 每盒数量 Quantity per box
- c. 包装日期 Date

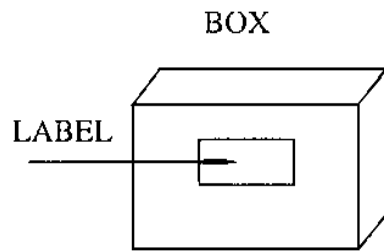

以上内容必须在标签上注明 (标签见 9.2 所示)。Above shall be shown on marking label(The marking label is shown in item 9.2).

4. 外包装箱标记 Marking on outer case:

- 1) 制造商 Manufacturer: "Shinhom"①
"中国制造" "Made in CHINA"②
- 2) 发运标记 Ship marking:
"向上" "UP", "小心轻放" "HAND CARE", "防潮" "MOISTURE-PROOF".
- 3) 包装标签包括以下内容 Packing label include the following:

- a. 型号 Part No
- b. 总数量 Total quantity per case
- c. 包装日期 Date;

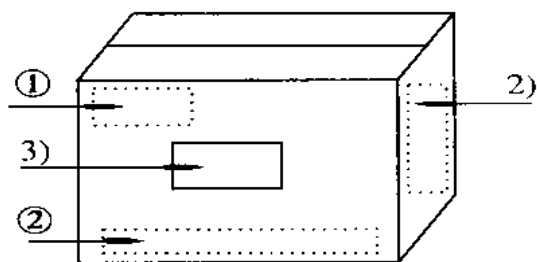

以上内容必须在标签上注明。(参见 9.2 所示)

All above shall be shown on marking label.

(The marking label is shown in item 9.2)

10 保管 Storage

①. 保管期限 Storage period

距我司出厂检验时间六个月内，产品可以使用；检验时间可以通过包装外侧标记的检验号确认；若时间超出六个月，应检查焊接性能后方可使用。Products which inspected in Shinhom over 6 months ago should be examined and used, which can be confirmed with inspection No. marked on the container. Solder ability should be checked if this period is exceeded.

②. 保存条件 Storage conditions

●存放货物的库房应满足以下条件 Products should be storage in the warehouse on the following conditions

温度 Temperature:10~ 40°C

湿度 Humidity : 30~70% relative humidity

不允许温、湿度有极剧变化。No rapid change on temperature and humidity

●禁止将产品保管在腐蚀性物质中，例如硫磺、氯气或者酸，否则将引起端头氧化，导致降低焊接性。Don't keep products in corrosive gases such as sulfur, chlorine gas or acid, or it may cause oxidization of electrode, resulting in poor solder ability.

●为了避免受潮气、灰尘等物质的影响，产品应保管于货架上。Products should be storage on the palette for the prevention of the influence from humidity, dust and so on.

●产品保管在库房中时，应避免热冲击，振动以及直接光照等等。Products should be storage in the warehouse without heat shock, vibration, direct sunlight and so on.

●产品应密封包装 Products should be storage under the airtight packaged condition.