



SHAANXI SHINHOM ENTERPRISE CO.,LTD

PULSE GATE DRIVE TRANSFORMER

These transformers are wound on high quality ferrite core and are intended for a very wide range of applications:

- firing thyristors and triacs;
- driving bipolar transistor and IGBT;
- driving FET and MOSFET transistors;
- line coupling in high speed data transmission (for the smallest sizes).

Three case sizes are presented, with increasing power rating, so that they can effectively find use as drivers in any low-to-medium power circuit for control and conversion of electrical energy, where the following features are requested at the same time:

- high power pulse transmission capability (high amplitude with proper duration) and low magnetization current;
- low leakage inductance, which allows high steepness and short rise time of the wave form;
- low coupling capacitance, so that a good decoupling and immunity to interferences is reached;
- small size, achieved with the use of toroidal core;
- high primary to secondary withstanding voltage by means of a proper wires insulation and rosin filling;
- international standards compliance.



Symbol Definitions

Turns Ratio (n)

Turns ratio of the primary winding to each secondary winding; first digit refers to the primary.

Voltage-time Area (U•t)

Minimum Voltage-time product of the pulse amplitude and pulse width, measured at half of the pulse height across the unloaded secondary in the unipolar mode.

Primary Inductance (PRI Induct)

Inductance of the primary winding measured at 10 kHz/0,1 mA (reference values only)

Primary Leakage Inductance (PRI Leak Induct)

Leakage inductance of the primary winding with secondary winding(s) connected in series and short circuited; measured at 100 kHz.

Winding Capacitance (PRI/SEC Cw/w)

Coupling capacitance between primary and secondary winding(s); measured at 10 kHz.

Primary Resistance (PRI DCR)

DC resistance of the primary winding.

Secondary Resistance (SEC DCR)

DC resistance of (each) secondary winding.

Test Voltage (Up)

Unrepeated test voltage at 50 Hz/1 to 2 sec, between primary to secondary winding(s).

Ignition Current (I c)

Reference current value giving a low voltage - drop under 1 V - across the secondary resistance.

Pulse Rise Time (Tr)

Rise time between 10% and 90% of the output pulse amplitude, measured on the secondary loaded with RL resistor.

Secondary resistor load (RL)

Working Voltage (Ueff)

Maximum rms working voltage of primary winding.



SHAANXI SHINHOM ENTERPRISE CO.,LTD

PULSE GATE DRIVE TRANSFORMER

CASE VERSION

Ignition current up to 100 mA

These small size and low power transformers are fitted on toroid cores of high performance (ferrite). The wide choice of inductance values and turn ratios make them suitable as drivers of thyristors, triacs, bipolar transistors or MOSFET's in a variety of high frequency applications, such as small power supplies, inverters etc., or also as couplers in high speed data transmission.

Dimensions in mm
Pins are tinned

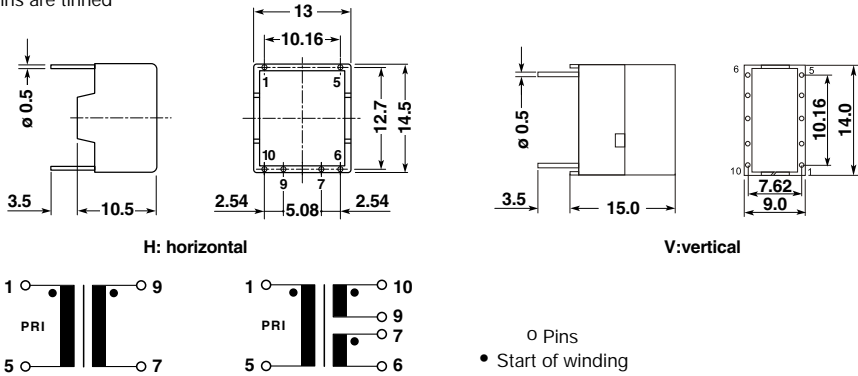

TYPES

Code	Turns ratio $n \pm 2\%$	$U \cdot t$ Vµsec min.	Tr µsec max	PRI Indut mH	PRI Leak Induc µH	PRI/SEC Cw/w pF	PRI DCR Ω	SEC DCR Ω	Ueff V	Up kV
GT12V/H-101	1:1	65	0.05	1.0	1.5	35	0.20	0.20	250	2
GT12V/H-102	2:1	50	0.05	2.0	3.0	30	0.30	0.15	250	2
GT12V/H-103	1:1:1	45	0.05	0.5	0.8	24	0.15	0.15	250	2
GT12V/H-104	1:1	40	0.05	0.15	0.7	24	0.07	0.07	600	4
GT12V/H-105	1:1	45	0.05	0.5	0.7	30	0.08	0.08	600	4

Turns ratio: first digit refers to the primary.

Symbol definitions p. 2

Tr is measured with $R_L = 100 \Omega$

Other type can be supplied according to customer's specifications.

Technical Data

Climatic category: DIN GKC (-40 to +125°C; humidity cat. C)
 Overtemperature of the windings: <55°C
 Max. windings temperature: 115°C
 Approx. weight: 3 g

The transformers are designed and tested in accordance with EN 138100; EN 60938-1
 The cases are of flame-retardant plastic material in accordance with UL 94V-0